

## MAIN SPECIFICATIONS

Model		7FBR10	7FBR13	7FBR15	7FBR18	7FBR20	7FBR25	7FBR30	7FBRS20	7FBRS25
Operator Position		Stand-up	Stand-up	Stand-up	Stand-up	Stand-up	Stand-up	Stand-up	Stand-up	Stand-up
Load Capacity	kg	1,000	1,250	1,500	1,800	2,000	2,500	3,000	2,000	2,500
Load Center	mm	500	500	500	500	500	500	500	500	500
Overall Width	A mm	1,090	1,090	1,090	1,090	1,190	1,190	1,240	1,190	1,190
Turning Radius (Outside)	B mm	1,320	1,470	1,560	1,710	1,750	1,950	2,000	1,750	1,950
Overhead Guard Height	C mm	2,250	2,250	2,250	2,250	2,330	2,330	2,330	2,330	2,330
Length to Fork Face	D mm	1,050	1,050	1,155	1,155	1,250	1,270	1,320	1,250	1,270

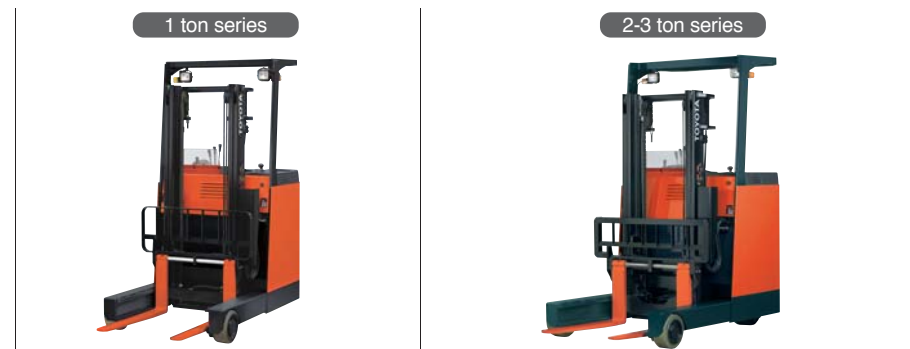

## BATTERY AND MOTOR SPECIFICATIONS

Model			7FBR10.13	7FBR15.18	7FBR20.25	7FBR30	7FBRS20	7FBRS25
Voltage/Capacity (5-hour ratings)	Min	V/AH	48/201	48/280	48/320	48/435	48/320	48/390
	Max	V/AH	48/225	48/370	48/435	—	48/435	48/435
Electric Motors	Drive	kW	4.9	4.9	5.2	5.2	5.2	5.2
	Load Handling	kW	8.0	8.0	11.0	11.0	11.0	11.0
	Power Steering	kW	0.26	0.26	0.35	0.35	0.35	0.35

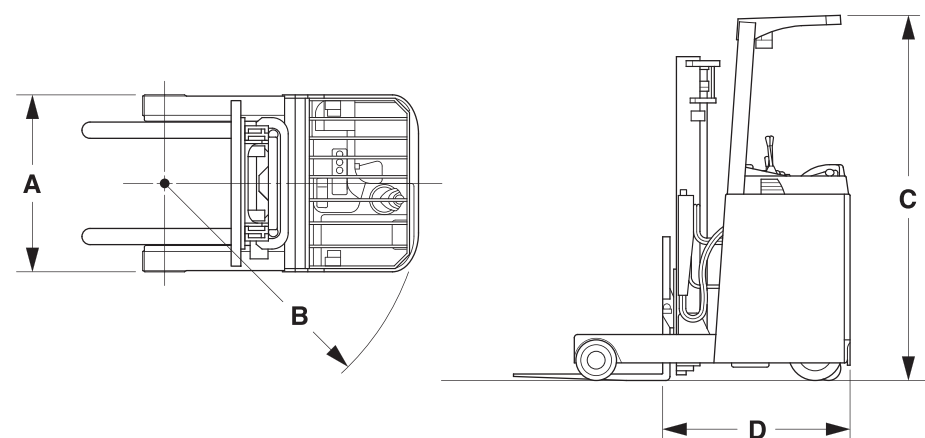

The data in this brochure is determined based on our standard testing condition.  
The performance may vary depending on the actual specification and condition of the vehicle as well as the condition of the operating area.  
Availability and specifications depend on region and are subject to change without notice.  
Due to photography and printing, color of actual vehicle may vary from this brochure. Some photos have been computer-enhanced.  
Please consult your Toyota representative for details.  
Photographs may include optional equipment.

All rights reserved by Toyota Industries Corporation.

# 7FBR

## SERIES



# Advanced Innovation, The Heritage of Toyota Philosophy

Toyota prides itself on its close communication with its customers. Going to the source is an aspect of **Genchi Genbutsu**, one of the Toyota Philosophies, and provides the ultimate inspiration for productivity-enhancing technology and design. Meet the 7FBR. It is just what you asked for and exactly what you are looking for. In it you will find the true meaning of Toyota innovations.

\* Genchi Genbutsu (現地現物) means going to the source to find the facts to make correct decisions to build consensus and achieve goals.



## Start with Safety

By using advanced engineering and time-proven know-how, Toyota offers superb stability for your operations.



## Built-In Efficiency

Toyota has developed advanced AC technology for reach trucks. The secret behind the 7FBR's high performance comes from the AC power system.



## Fatigue-Fighting Comfort

Toyota has realized the ideal ergonomics for reach trucks. The well-considered design will lead your operation to a higher level.



## Productivity PLUS

Each worksite and operator is different. Toyota respects these points and the 7FBR meets your demands by offering the productivity PLUS options.





# Start with Safety, A Wish from Toyota

Everyone wishes safe operation for the operator. Toyota, known around the world for the way it applies technology to support operation, is striving to provide superb solutions that make this wish come true. Advanced electronic technology gives the 7FBR good response for braking, traction control and stability.



## Traction Control

Traction Control automatically adjusts the torque output of the motor when the reach truck is starting and during switchback operations. This helps reduce drive wheel slippage. As a result, the operator does not need to make accelerator adjustments and can focus on safe and efficient operation. This system is especially helpful when traveling on slippery surfaces. And the reduced wheel slip will help extend the service life of the drive tire.

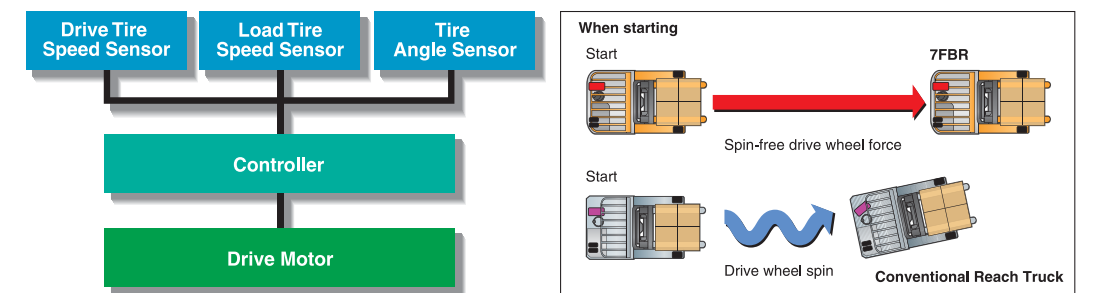

## Stable Suspension Control

Toyota has developed a System of Active Stability (SAS) specifically for reach trucks. An electronic controller is used to help maintain stability during travel and load handling. It gives you advanced control of the stability.

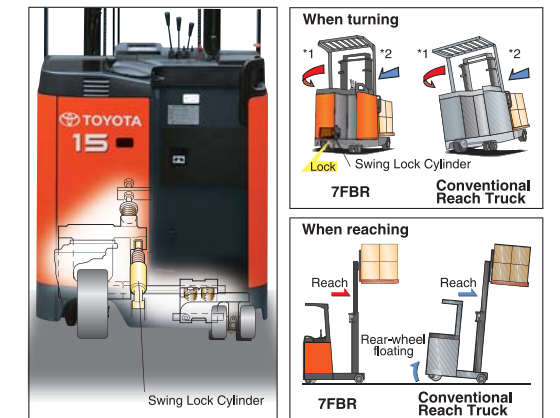

No Reduction in Capacity  
**Up to 4m**

## Front-Assist Brake System

An electronic controller determines the optimal amount of braking to be applied to the two front wheels. This system dramatically reduces swaying when the brakes are applied. It also provides good stopping performance on slippery surfaces. This brake control system contributes to safe and productive operation.

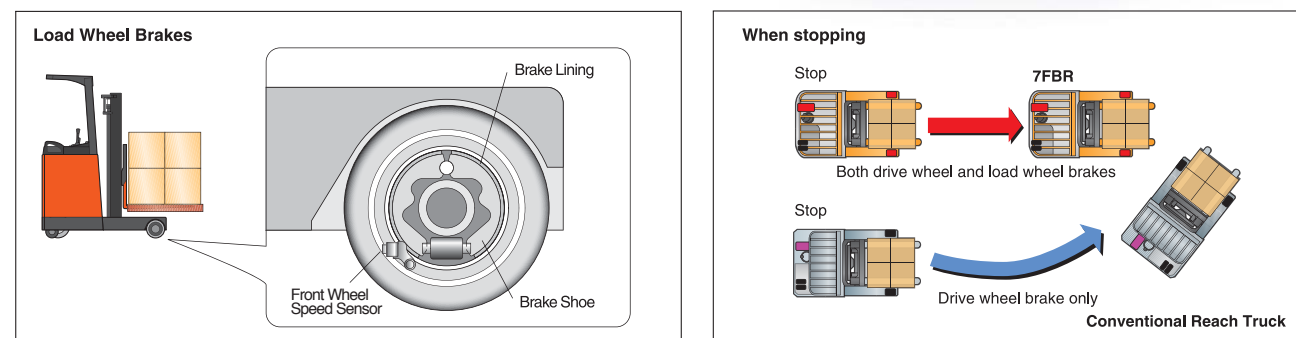

## Operator Presence Sensing (OPS) System

The travel and load handling controls become inoperative when the floor switch cannot detect the operator.

### OPS for Load Handling

Stops load handling when the operator is not on the reach truck.

### OPS for Traveling

Stops travel when the operator releases the brake pedal.



# AC Power System, Built-In Efficiency

Toyota developed this AC technology in its search for advanced efficiency in reach truck operation.

The AC power system provides the best performance needed for operations while optimizing power consumption. And this AC power system requires less maintenance than DC systems used on conventional reach trucks. With the 7FBR, the benefits of the AC power system are all yours.



## AC Power System

The AC power system has brought about a revolution in reach trucks. It enables flexible control of the electric power and its compact, high-power components give Toyota engineers more flexibility for ergonomic design. Let the 7FBR start a revolution at your worksite.

## Newly Developed AC Load Handling & Drive Motors

Newly developed AC load handling and drive motors are used on the 1-ton series. Each of these motors has a newly developed dedicated high-efficiency inverter that works in synergy with the main controller to provide precise load handling and travel control, powerful output and long operation per charge.

Operating Time 1.5 ton (S Mode)

7FBR 8 hours 10 minutes

NEW 7FBR 8 hours 55 minutes

Operation Time  
**10% UP**

Approximate value when new 7FBR 1-ton series (S Mode) is compared with the current series.

New 1 ton series

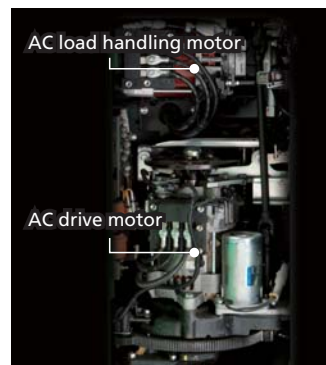

## Power Select Function

The operator can easily select from among three modes of performance to meet the exact needs of your worksite. The S-mode is the standard mode that offers performance that meets the needs of most worksites. The P-mode uses the power to give higher performance. The H-mode setting gives high performance with a priority on load handling speed. These power modes can be adjusted to your needs.

1 Ton Series



2 to 3 Ton Series

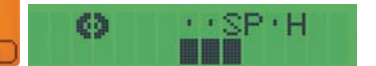

\* The operation modes affect the length of operation per charge. Please consult your Toyota representative for details.

## Power Keep Function

This function enables the 7FBR to keep its "just charged" performance longer. It will be able to provide vibrant performance even as the charge in the battery is getting lower. A longer period of robust performance equals more productivity.

Robust Performance **25% Longer\***

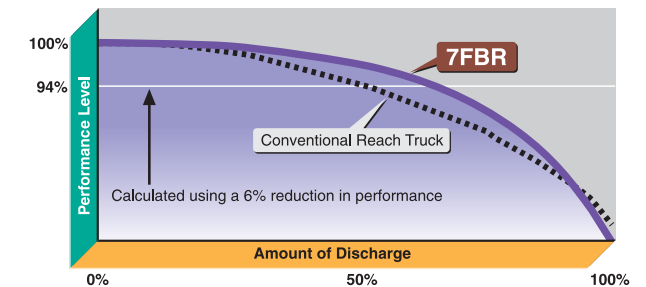

## Regenerative Braking Systems

The 7FBR uses a regenerative braking system to generate and collect power during the following operations.

- When accelerator lever is released
- During switchback
- During braking

This function can extend operating time per charge. It saves energy and helps our environment.

## Low Maintenance

AC components are innately low maintenance as the AC motor has no contactors and brushes. This is a major benefit for reach trucks that are required to perform frequent switchback operations. (Frequent switchback operations cause contactors and brushes to wear out quickly in DC motors.) Furthermore, the use of the AC load handling motor on the 1 ton series NEW 7FBR dramatically reduces costs.

Control System Maintenance Items and Estimated Costs

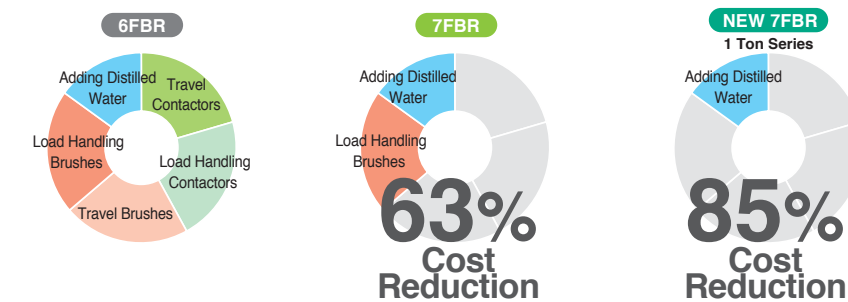

(Compared to reach truck with DC power system.)





# Well-Designed Comfort, Interface with Efficient Operation

The 7FBR shows how much Toyota respects the hard work of the operators. To make their work easier, Toyota carefully researches and analyzes how the reach truck is used and what the operating conditions are. Toyota ergonomics, low floor, easy-to-operate steering and low effort braking, lead your operators to their best productivity.

## Spacious Operator's Compartment

The operator's compartment is another example of Toyota listening to what the operators have to say. A low floor means a lot to an operator who gets on and off of the reach truck repeatedly during a shift. And the ample head clearance keeps the operator from feeling cramped.

Floor Height (7FBR10-18)  
**250mm -60mm\***

Floor Length (Front to Back) (7FBR10-18)  
**425mm +50mm\***

Floor Width (Side to Side) (7FBR10-18)  
**540mm +40mm\***

Head Clearance (7FBR10-18)  
**1,960mm +50mm\***

\* Compared to 6FBR.



\* Compared to 6FBR.

## Angled Lower Backrest Stay

Optimizing the angle of the lower stay on the backrest provides the operator with a clear view of the fork tips, which makes it easier to insert the forks into a pallet on the ground.



## Small-Diameter Steering Wheel

The small-diameter steering wheel and Electronic Power Steering (EPS) team up to provide precise and comfortable operation. This steering system helps boost productivity while reducing operator fatigue.

Radius to Knob  
**100mm -40mm\***

\* Compared to 6FBR.



## Easy-Down System

This function helps reduce noise when the forks contact the ground. The speed of the lowering forks will automatically slow down just before contacting the ground – even when the lift lever is in the full down position.



\* Available for V and SV mast

## Waist Support

The waist support is designed to provide a firm support to the operator, contributing to comfortable operation.



## Easy Operating Brake

The brake pedal requires very little effort to depress. On a reach truck, the operator pushes the pedal down during traveling and releases it for braking. Less effort to depress the brake pedal means less operator fatigue.

Brake Pedal Effort (7FBR10-18)  
**40% Less\***

\* Compared to 6FBR.

**OPT**

## Document Box / A4-Size Binder A4-Size Binder with Clear Cover Storage Box with Cup Holder

This conveniently located document box/binder can hold A4 size documents. The binder with a clear cover can protect the documents from getting wet. The storage box can keep small items.



Document Box    A4-Size Binder    A4-Size Binder with Clear Cover    Storage Box with Cup Holder

# Precise Operating Information Enhances Efficiency

The Multifunction Display is an easy-to-use, comprehensive system that accurately conveys information about the 7FBR, enabling the control that makes it an outstanding partner at a wide range of work sites.

## Multifunction Display DX **New** 1 ton series

The clear and detailed graphic LCD and LED display enables the operator to easily monitor information essential to the operation of the 7FBR. This display shows travel speed, battery capacity and other crucial information and also enables the operator or a manager to set the performance levels of this reach truck.

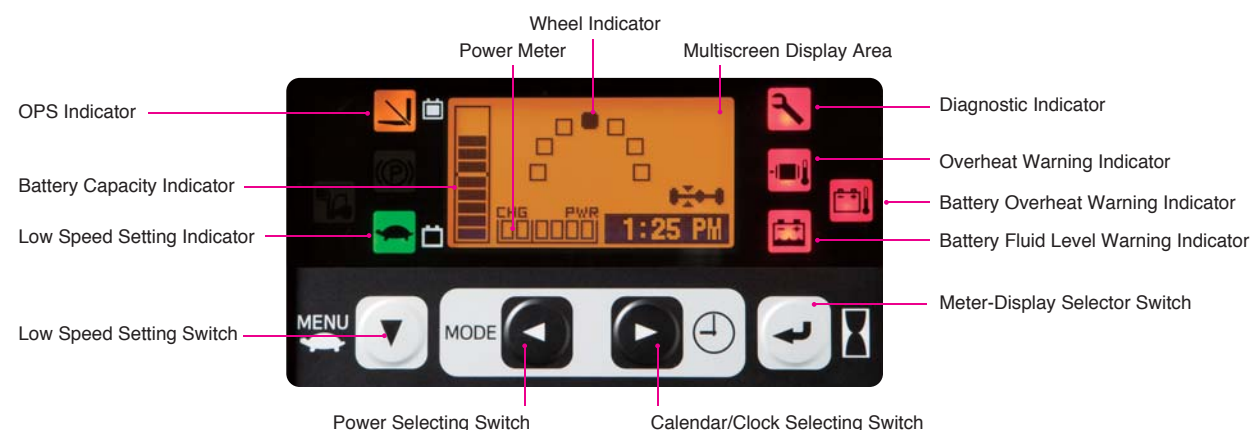

## Digital Multifunction Display 2-3 ton series

The hour meter, 2-speed travel speed control and other features are standard. This display provides easy-to-notice warnings of abnormalities in the reach truck in addition to enabling the monitoring of many other conditions.



## Hour Meter 1 ton series **STD** 2-3 ton series **OPT**

This meter shows key-on time, the amount of time the travel and load handling functions were used and can calculate the distance traveled. Such information supports the management of the reach truck.

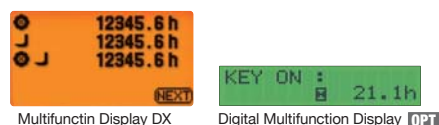

## Over Speed Alarm 1 ton series **STD** 2-3 ton series **OPT**

The speed display will flash and an audible warning sounds whenever the travel speed exceeds the preset level, encouraging safe operation.



## Battery Protecting Function (with Accumulating Power Consumption Meter) **New** 1 ton series **OPT**

When this function detects low battery fluid level or battery overheat, it sends a warning to the operator and restricts the performance of the reach truck, helping to minimize damage to the battery.



The amount of energy consumed during charging and the calculated amount of CO<sub>2</sub> emissions during the generation of that electricity are displayed to support in energy management.



# The Key to Difference, Productivity PLUS Options

Productivity PLUS options are ready to meet the special conditions at your worksite. Select the right options and you will see a big difference in the productivity at your worksite.

## Cold-Storage Model **OPT**

The 7FBR offers cold-storage models that enable it to withstand the extremely low temperatures found in cold-storage warehouses.

### Cold-Resistant Components

Uses cold-resistant hydraulic hoses, seals, oils and lubricants to withstand the environment inside and outside of the cold storage area.



### Water- and Rust-Proof Components

Chrome-plated levers along with special rust-fighting coatings and paints are used. Specially designed electronic components offer outstanding water resistance.



## Laser Marker **OPT**

A bright laser marks the height of the forks. The Laser Marker supports smooth pallet handling in the warehouse.



\* This is an image photo. The actual appearance of the laser beam is different.

## LED Headlight **OPT**

LEDs provide bright illumination with far less power consumption and offer considerably longer life.



## Rear Rubber Bumper **OPT**

In the rare event of a mishap, the D-shaped rubber bumper helps reduce damage.



## Load Meter 2-3 ton series **OPT**

Load Meter is optionally available on the Digital Multifunction Display. It provides the approximate weight of the load when the operator releases the lift lever.



\* The indicated values are not for commercial use.

## Operator Side Protector **OPT**

This steel protector helps to guard the operator's shoulder and elbow from harm.



## Resin Roof **OPT**

Easily detachable roof helps provide protection from small falling objects. It is also effective against rain showers.



## Multifunction Lever **OPT**

All reach truck operations can be controlled by this lever. The Multifunction Lever will surely support the productivity of all levels of operators.

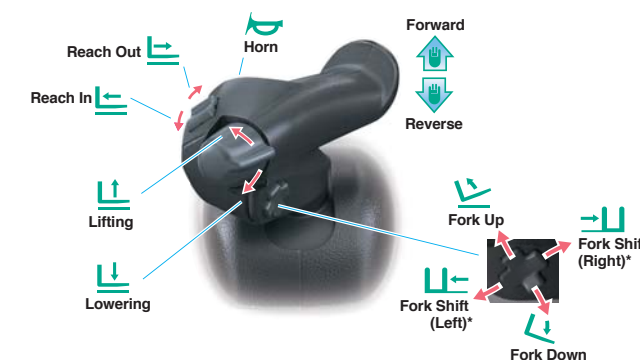

\* With optional Side Shift Fork attachment.